



E-Vision Frame Grabber RGB100



Product Type: RGB100

Introduction

RGB100 is high-precision and professional frame grabber based on PCI BUS for standard or non-standard RGB color separated acquisition. Image data is captured into the EMS memory with Scatter/Gather DMA mode, no occupying CPU, so it is very suited for kinds of standard or non-standard cameras with progressive or interlaced scanning, X-Ray Machine, CT, nuclear-magnetism and other medical treatment image equipments.

Functions

- | 32-bit/33MHz PCI BUS
- | Frame Buffer, three channels of 8 bits AD with high speed, high precision and high SNR
- | One channel RGB signal input and one output
- | Progressive or interline scanning
- | Line rate of sampling capture could be adjusted, and the maximum rate could be 100M
- | Maximum resolution is 1024 x 768 @ 85Hz
- | Measure line and field automatically
- | Support RGB16, RGB24, RGB32 and GRAY8
- | Pixel jitter is less than 0.5ns
- | Three independent resist-confusion filters which can adjust bandwidth
- | The brightness and contrast of three channel of RGB could adjusted independently
- | Capture Single field, single frame and continual frame, and the precision is field
- | Trigger input(Low level of TTL is valid)
- | Maximum consumption: 3.3 W



System requirements

- 1 The computer main board must conform to the real PCI2.1 standard regulation;
- 2 Using processor Pentium or better series which could make better performance;
- 3 Please distinguish between 24 and 32 bit VGA video card according to your image card instruction.
- 4 In order to get better dynamic video, the minimum of EMS memory is 64M while the minimum of display memory is 8M.
- 5 More than 20M hard disk space is needed to install driver and run programme normally.
- 6 Win98/Win2000/Win XP Systems.
- 7 Please make sure that there is no virus in the computer and check your System Device Manager such as if there is other video capture products and drivers, if there is interrupt conflict, if the original driver of your image card is installed accurately...

8 Do not pull out or insert product if the power supply is on at any time, especially for the video in and out cable! If you need to pull out or insert, please shut down all the power supply, or it will be damaged!

Principle Structure Drawing

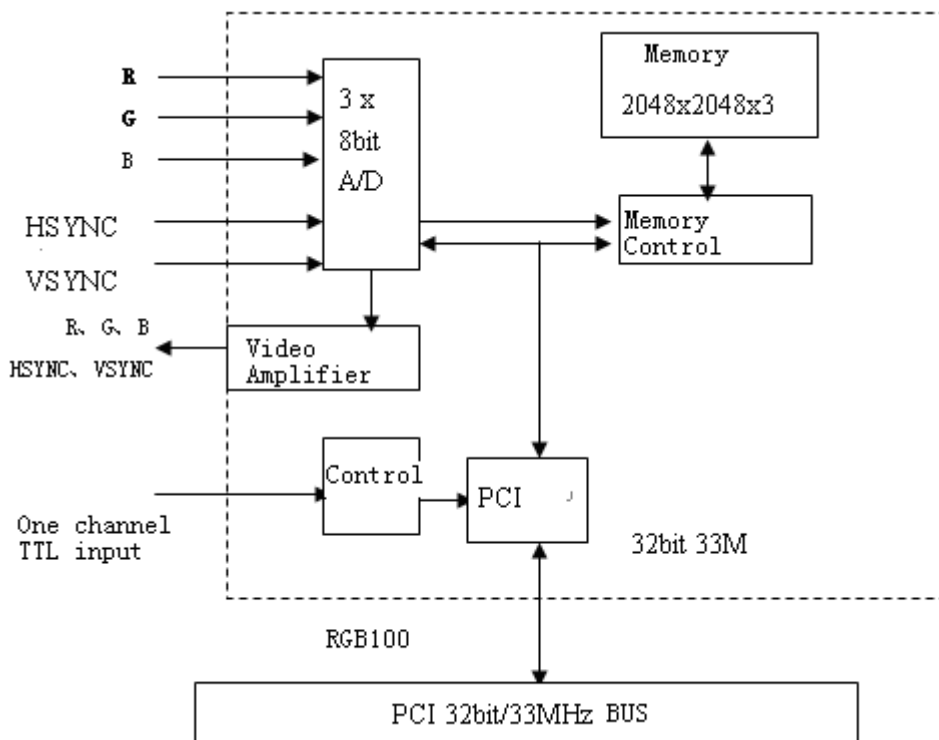



Board Layout and Pins Definition

The board layout is as the following drawing, and you can find the interface and pins for all kinds of video signals on the image card:

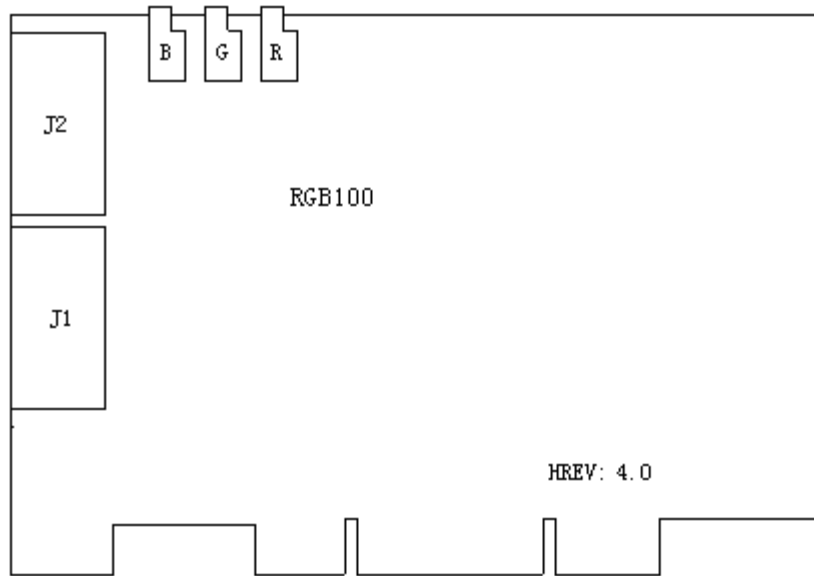

1. Interface and Pin definition:

- a) J1:15pins for R、G、B input;

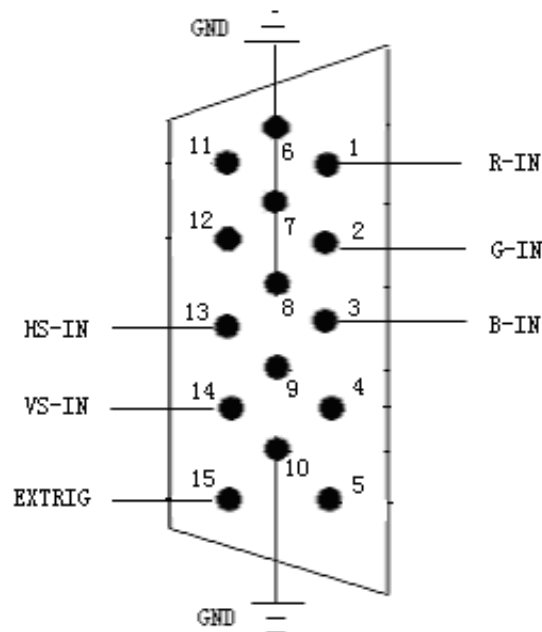



- b) J2:15pins for R、 G、 B output;

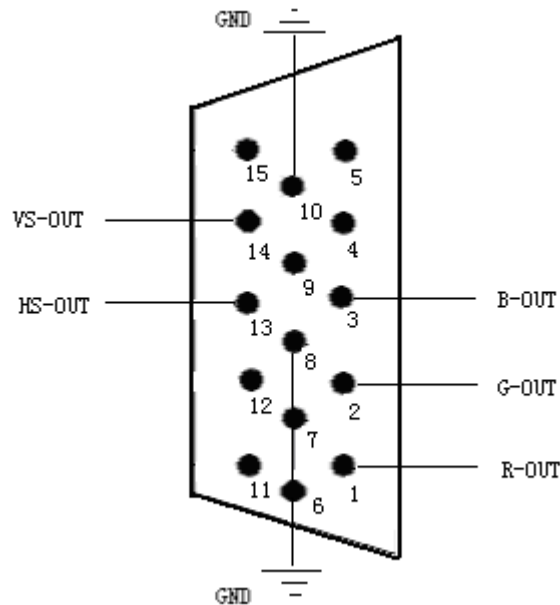

2. Adjustable resistance R、 G、 B: User could adjust the amplitude of output signal by adjusting the resistance value;

a) User could adjust regulation resistance R value to adjust the amplitude of red signal output:
turn clockwise to small the amplitude while turn inhour to large the amplitude

b) User could adjust regulation resistance G value to adjust the amplitude of green signal output:
turn clockwise to small the amplitude while turn inhour to large the amplitude

c) User could adjust regulation resistance B value to adjust the amplitude of blue signal output:
turn clockwise to small the amplitude while turn inhour to large the amplitude

* The default value of the three signal amplitude is 0.7V while the frame grabber is out office;

Connecting Cable

- Ø Input cable:15pins
- Ø Output cable:15pins

Card Size

- Ø Vertical :102.3mm
- Ø Horizontal: 151.3mm



Operating Temperature

0°C~55 °C(32 F~131 F)

Relative Humidity

No more than 90% (No fog)